

CS276D



S.A. CASSESE
Z.I. - 77390 VERNEUIL L'ETANG
SIREN 308 305 333 00038
S.A. au capital de 5 000 000 F
Téléphone : 01 64 42 49 50
Fax • 01 64 42 58 90

CASSESE SA Zone Industrielle - F 77390 VERNEUIL L'ETANG

Telecopie : (1) 64 06 04 19

SUMMARY

INTRODUCTION

1 -Introduction.....	Page 1
2 - Accessories.....	Page 1
3 - Specifications.....	Page 1
4- Options.....	Page 1
5-Guarantee.....	Page 1
6 - Drawing.....	Page 2

INSTALLATION

1 - Reassembly.....	Page 3
2 - Hood.....	Page 4
3 - Connecting the machine.....	Page 4

ADJUSTMENTS

1 - Adjusting the sliding table.....	Page 5
2 - Selecting the joining position.....	Page 5
3 - Selecting the number of wedges.....	Page 7
4 - Choice of wedges.....	Page 7
5 - Installing or changing the wedge cartridge.....	Page 7

USE

1 -Positionning the bung.....	Page 8
2 - Assembling the frame.....	Page 8

DIFFERENTS ADJUSTMENTS

1 - Adjusting the assembly corner.....	Page 9
2 - Adjusting the claws.....	Page 9
3 - Adjusting the limit stop inclination.....	Page 10
4 - Adjusting the end of travel limit stop.....	Page 10
5 - Disassembling the sliding table.....	Page 11

MAINTENANCE

1 -Changing the hammer.....	Page 12
2 - Maintenance of the "wedge disribution" part.....	Page 13
3 - Maintenance and lubrication.....	Page 13
4 -Removing a jammed wedge.....	Page 13

FAULTS - REMEDIES.....Page 14

SPARE PARTS LIST

1 - List.....	Pages 15/16
2 - Plan.....	Page 17

II - HOOD

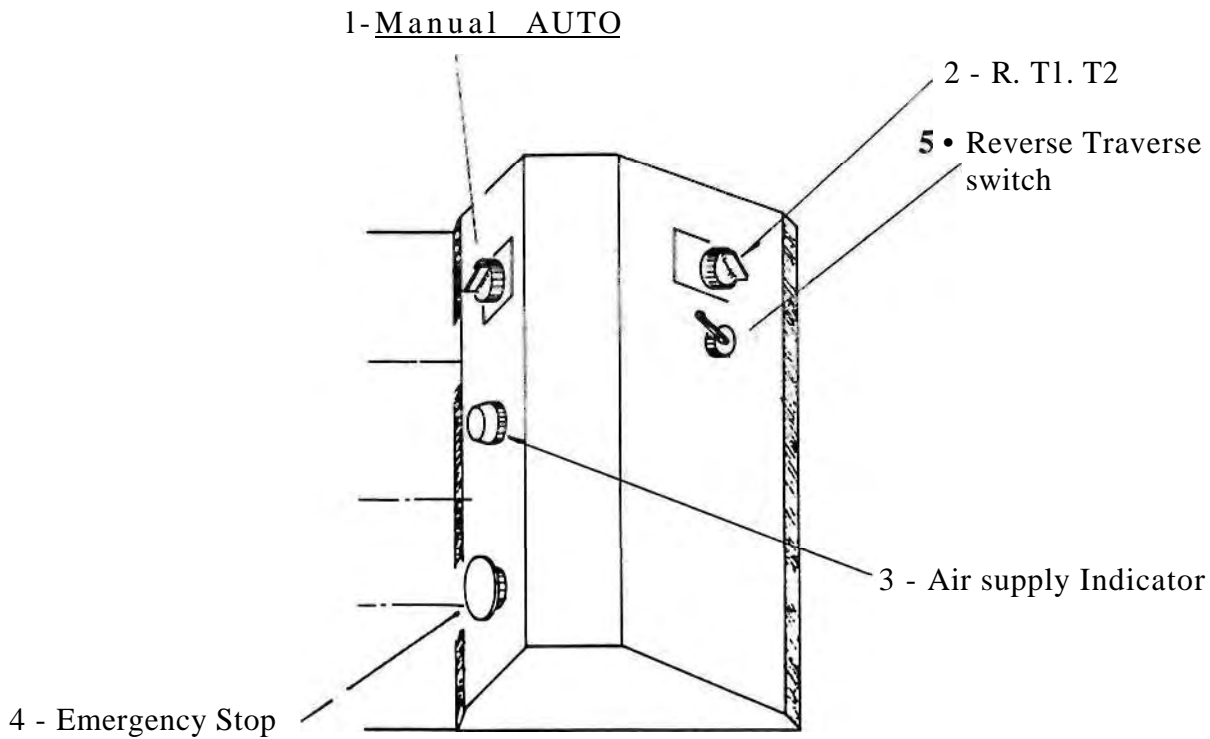

FIGURE 3

- 1 - Selection of automatic or manual cycle
- 2 - Selection of the number of wedges at the first stapling position
- 3 - Air supply indicator
- 4 - Emergency stop button
- 5 - Reverse traverse switch.

III - CONNECTING THE MACHINE

- a) Connect the air pipe to the machine using the snap connector provided for this purpose
- b) Connect the air compressor
- c) Open the air valve on the pressure reducer on the outside of the machine
- d) Check that the manometer pressure is at least 6 bars.

INSTALLATION

I - ASSEMBLY

- 1 - Assemble the four machine feet (these are packed with the accessories).
 - 2 - Assemble handles X, W and B (Fig. 1) replacing the transportation bolts, but do not lock them.
 - 3 - Reposition bracket E in the normal position since this was lowered on tables M and M' for transport (see Fig. 2).
- Unlock rings I and J on vertical columns K and L (Fig. 2).
 - Unlock the lower limit stop attachment bolt F and rotate it through 90°.
 - Engage the hammer and its support G into the joining sub-assembly, lifting the stapling cylinder Ref D until the bottom of the hammer support is over the lower limit stop and then reposition the latter below the hammer support by rotation it.
- 4 - Remove the grease tube fixed to the cylinder inside the machine.

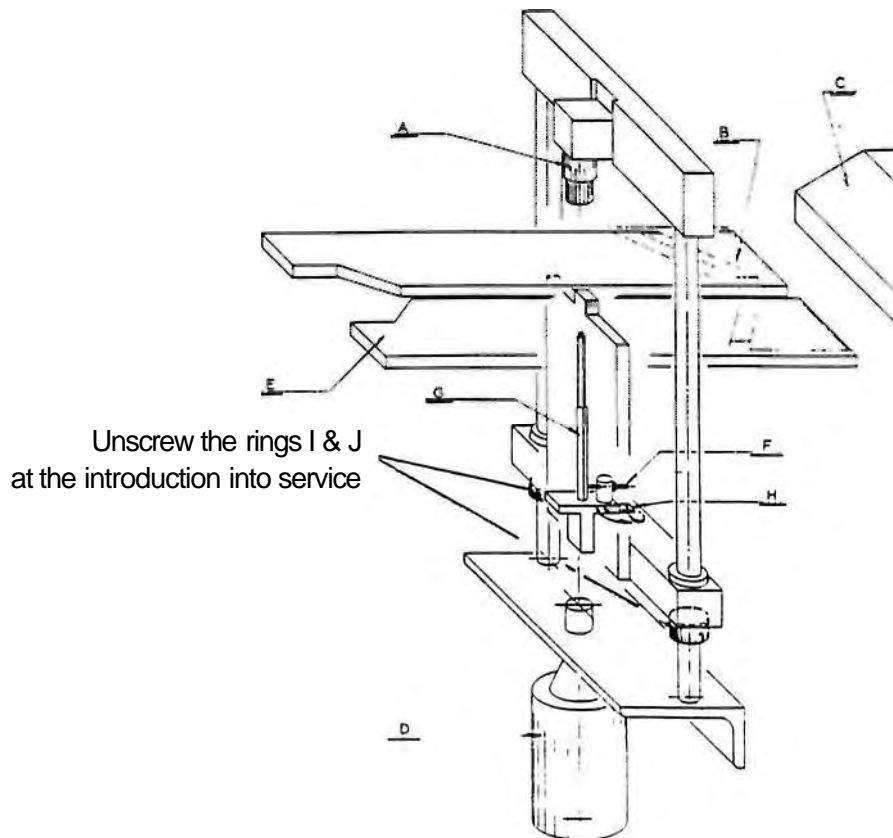

FIGURE 2

IMPORTANT : We recommend that you carry out the machine adjustment and start up operation in the order defined in this document in order to optimize operation of the 276 D.

ADJUSTMENTS

I - ADJUSTING THE SLIDING TABLE (see Fig. 1)

- 1 - Lower the lever (J) on the back of the machine in order to advance claws Q and P and position button 2 Fig. 3 on R.
- 2 - Check that the 2 buttons K and K' (fence inclination) and the 90° adjustment (knurled knob L) are set to zero.
- 3 - Position the moulding (for mouldings with a height less than the fence height, the set of metal bars supplied with the accessories must be slid into contact with fences M and N), then position the moulding to be assembled against them.
- 4 - Move the sliding table until claw Ref. Q Fig. 1, comes into contact with the moulding.
- 5 - Tighten the locking handle (B).

II - SELECTING THE JOINING POSITION

The 276 D is designed to join mouldings at 1 or 2 locations with a maximum of 2 wedges at the first position and an unlimited number in the second position.

The choice is made as a function of the width and thickness of the mouldings to be assembled.

Note : In all cases the wedges must be installed as close as possible to the highest part (s) of the moulding (see Fig. 4)

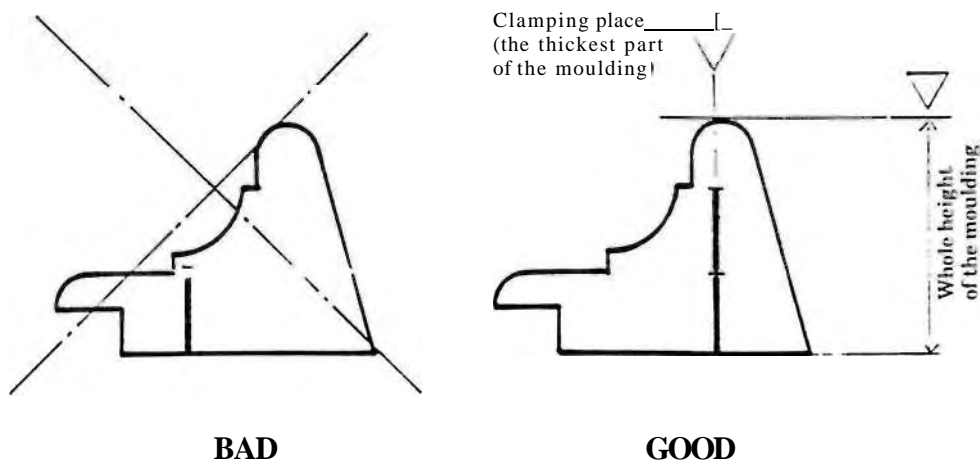

FIGURE 4

1 - Unlock handles X and W

- a) First joining position : outside edge of frame :

Slide bracket (E) backwards until reaching the selected joining position, and move handle W towards the front limit stop and lock it.

- b) Second joining position : inside edge of frame :

Slide bracket (E) forwards until it reaches the joining position, move the X handle to the back limit stop and lock it.

2 - Lift lever J

III - SELECTING THE NUMBER OF WEDGES AT THE FIRST JOINING POSITION

A - CHOOSING THE FIRST LOCATION :

Select the position of the first wedge (s) with the reversing lever Rep 2.

B - Select the number of staples at the first position with knob 5.

R - Switches the head traverse power supply off so that it can be manually moved.

T1 - For 1 staple before traversing.

T2 - For 2 staples before traversing.

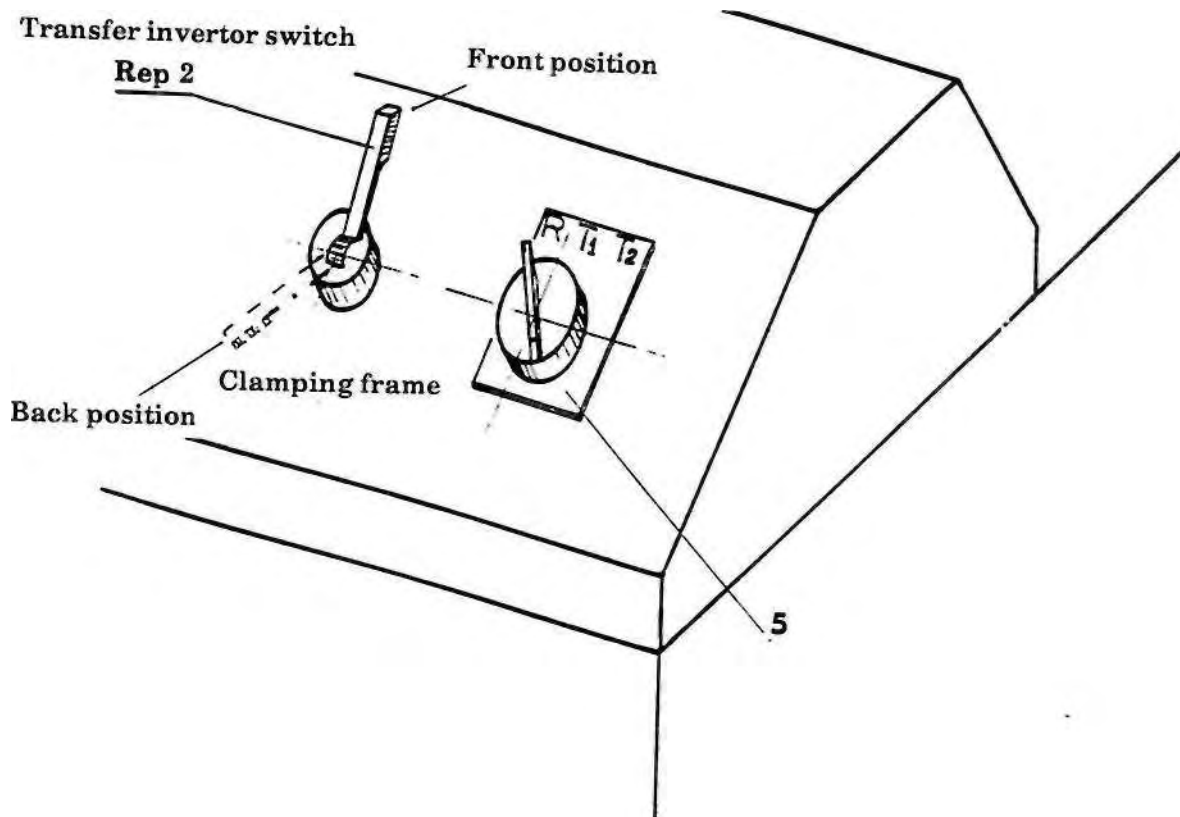

FIGURE 5

ADJUSTMENTS

IV - CHOICE OF WEDGES

The size of wedges (5, 7, 10, 12, 15 mm) will be selected as the function of the height of the mouldings to be assembled.

The wedge type is selected as a function of the materials to be assembled.

- When normal wood wedges are not suitable for the assembly (if they break or project through the back of the moulding), special hardwood wedges (BD) should be used.

In general a minimum of 2 mm clearance is recommended.

Example : 12 mm thick moulding = 10 mm wedges.

Note : Wedges with the same dimension may be superimposed, avoiding the need to change the wedge cartridge if assemblies of different thickness frames are made.

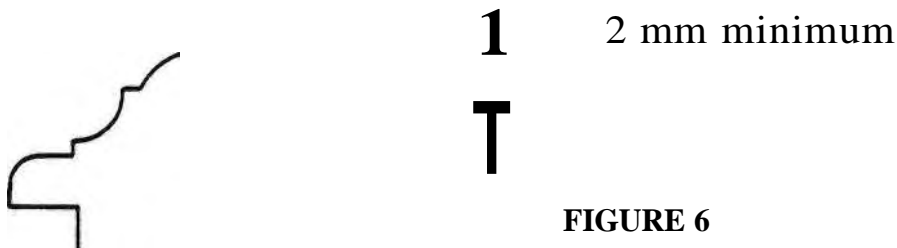

FIGURE 6

V - INSTALLING OR CHANGING THE WEDGE CARTRIDGE (FIGURE 1 - REF. FA).

- 1 - If necessary, remove the strips placed in front of fences M & N (Fig. 1).
- 2 - Loosen lock nut Ref. G on the tension bar Ref. F and lift the bar (Fig. 7) to its fullest extent.
- 3 - Remove the empty cartridge by pulling it towards the back of the machine.
- 4 - Fully engage the cartridge in the distributor window.
- 5 - Completely lower tension bar F and lock it using locking bolt G.

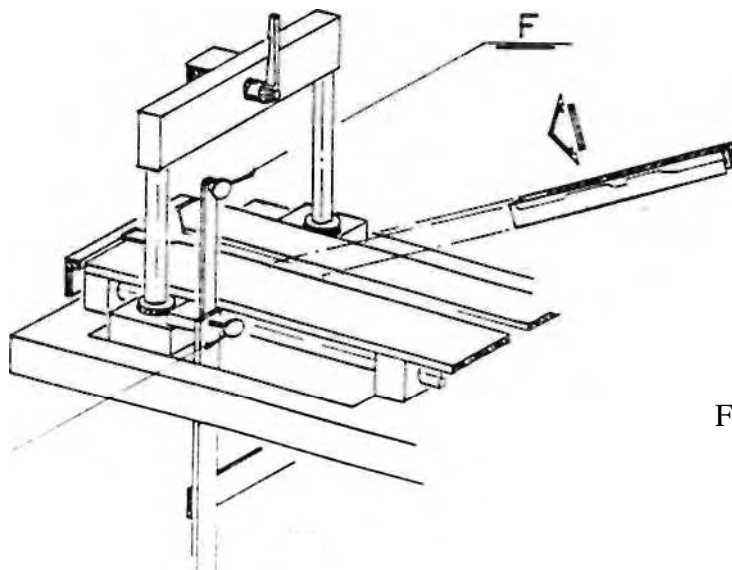

FIGURE 7

USE

I - POSITIONING THE BUNG

- Check that the travel between the top of the mouldint and the bottom of the bung does not exceed 40 mm (Fig. 8)

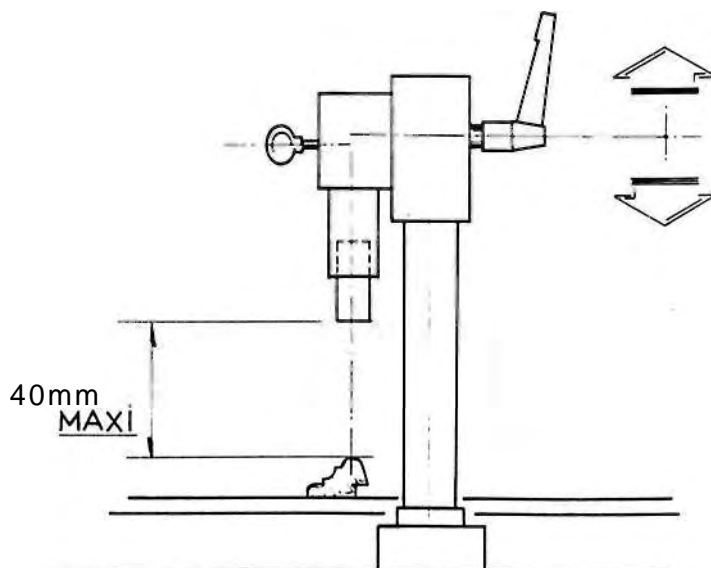

FIGURE 8

Otherwise, adjust the position or use the corresponding bung (see page 1 - "INTRODUCTION")

II - ASSEMBLING THE FRAME (FIG. 1).

* **Assembly in manual position (MAN):**

- 1 - Position the first moulding against fence M and slide it until it reaches fence N.
- 2 - Still holding the first moulding, position the second moulding against fence N and slide it until it comes into contact with the first

DESCRIPTION OF AUTOMATIC AND MANUAL CYCLES :

MANUAL:

Press the pedal to clamp the mouldings, then press the operating button once for one wedge. The number of staples is limited to two at the first joining position (position before the head traverses) and is unlimited at the second position.

AUTOMATIC:

Press the pedal to clamp and the first wedge is then driven. Press the operating buttons if a second wedge is required. (Number of wedges limited to two on the first position) wedges are driven at the second position by pressing the operating buttons. It is essential to keep the pedal pressed throughout the cycle until the last wedge has been driven.

I - ADJUSTING THE ASSEMBLY CORNER (FIGURE 9)

If the corner is open at the outside, screw the adjustment bolt (Fig. 10 Ref. L) to correct the fault and check the adjustment by clamping the mouldings (MAN position, press on pedal).

T Corner open at outside

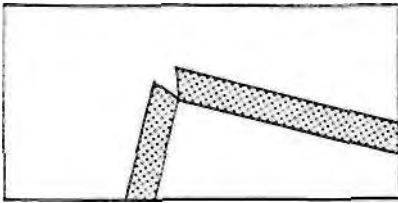
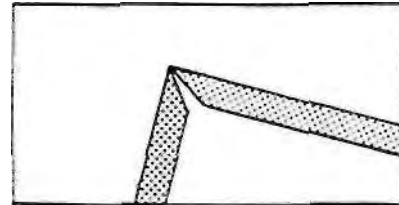
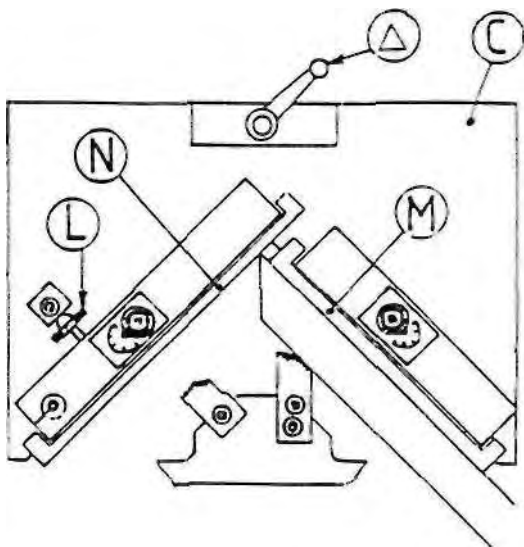

FIGURE 9



• Corner open on inside

If the corner is open on the inside, unscrew the angle adjustment bolt (Ref. L - Fig. 10) in order to correct the fault.



T If you obtain this result, check your cutting angle which must be bad since it is less than 45° *

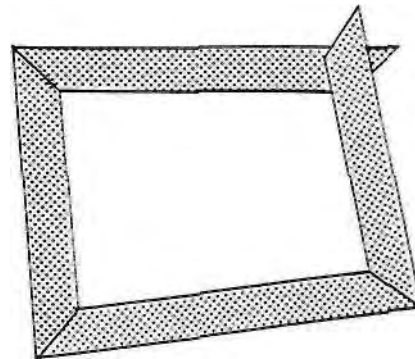

A FIGURE 10

* Adjust the angle of your cutting machine

II - OFFSETTING THE 2 ASSEMBLED MOULDINGS : ADJUSTING THE CLAWS (FIG.II)

If the mouldings are offset when they are tightened, the pressure adjustment knob must be adjusted (Ref. R-Fig. 1).

• Increase the claw pressure P by screwing: in R, reduce the general pressure by unscrewing knob S.

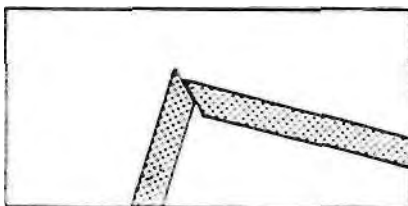
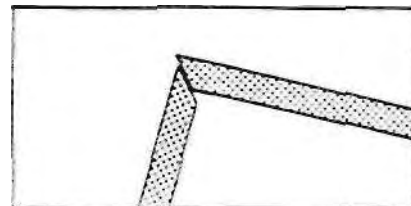

Figure 11



• I Increase the claw pressure Q by unscrewing in knob R or screwing in Knob S.

Apply glue before making this adjustment if mouldings are to be glued. Correct tightening can be checked by the depth of the impression left by the claws in the mouldings (about 0 to 0,4 mm depending on the hardness of the wood).

III - ASSEMBLY CORNER OPEN AT TOP OR BOTTOOM : ADJUSTING THE FENCE INCLINATION

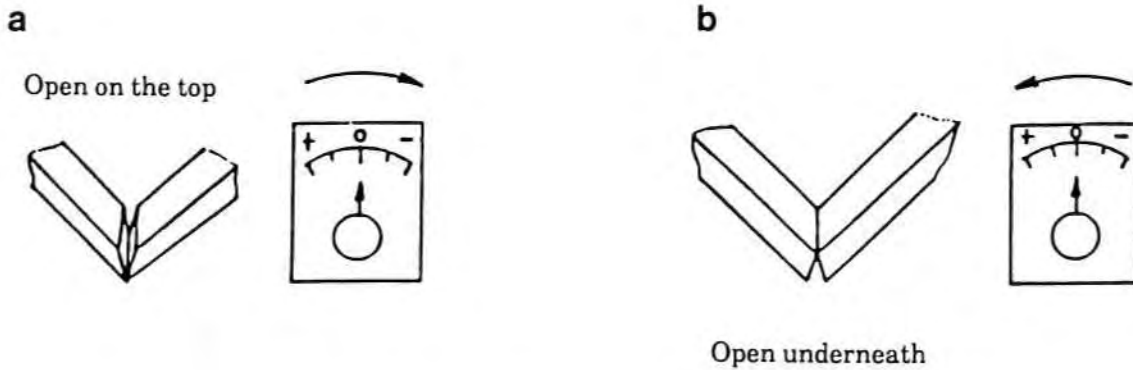

FIGURE 12

* If the assembly is open at the top (Fig. 11 a) rotate the two adjustment knobs K by the same amount towards the **minus**.

* If the assembly is open at the bottom (Fig. 11 b) rotate the two adjustment knobs K by the same amount towards the **plus**.

* Immediately press the emergency stop button if the bung stays down and exerts a high pressure on the moulding.

PROBABLE CAUSES :

* Jammed wedge (see solution Page 13 - Fig. 15).

IV - ADJUSTING THE END OF TRAVEL LIMIT STOP (Fig. 13)

- 1 - Remove the wedge cartridge.
- 2 - Screw in the end of travel limit stop Ref. V.
- 3 - Disconnect pipe Ref. U from the end of travel detector Ref. P.
- 4 - Pass your hand under staple cylinder Ref. Y and lift it until the end of travel limit Ref. V touches the end of travel detector sensor Ref. P. If detector Ref. P outputs zero pressure, unscrew the end of travel limit stop by a quarter of a turn and repeat the operation until the detector outputs an **air** pressure. When the detector outputs pressure, unscrew the end of travel limit stop by one more half-turn and then reconnect tube U to the end of travel detector Ref. P.

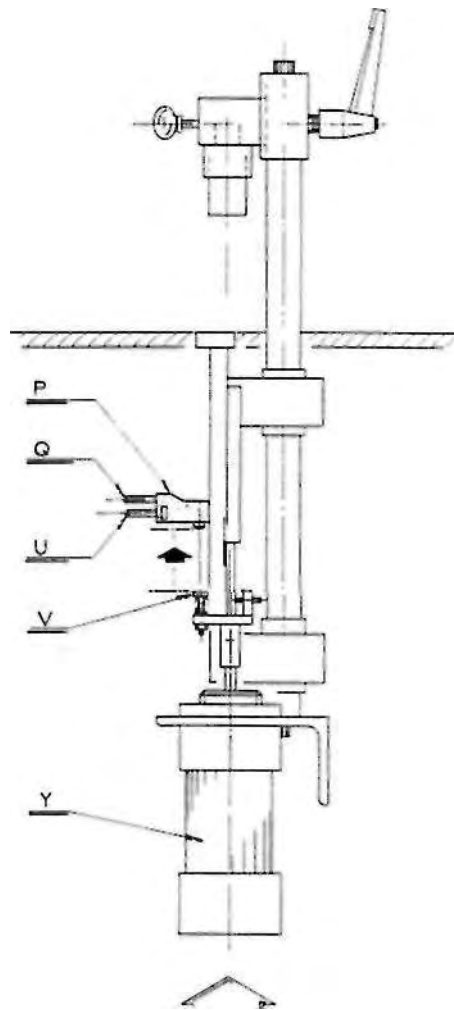

FIGURE 13

V - DISASSEMBLING THE SLIDING TABLE

If the sliding table has to be disassembled (for example for cleaning) unscrew the locking handle and release the table **holding it with the two fence inclination knobs.**

MAINTENANCE

I - CHANGING THE HAMMER (Fig. 14)

TURN OFF THE AIR SUPPLY BEFORE CARRYING OUT ANY WORK

The hammer is the part which pushes the wedges through the subassembly to be joined.

PROCEDURE:

- 1) Remove the wedge cartridge in the machine.
- 2) Remove the bung support Ref. A.
- 3) Completely withdraw the sliding table Ref. C towards the hood.
- 4) Unlock the lower limit stop bolt Ref. H.
- 5) Put your hand under staple cylinder Ref. D and lift it.
- 6) Pivot the lower limit stop Ref. H through 90° and allow the cylinder to drop until the bracket rests on plates Ref. E.
- 7) Unscrew the hammer retaining screw Ref. F and remove it.
- 8) Install a new hammer, taking care to place the hole in it on the retaining screw Ref. F end piece and then screw the pin in completely taking care not to lock it; stop tightening when it reaches the bottom.
- 9) Grease the hammer and the hammer support Ref. G.
- 10) Engage the hammer and the hammer support, lifting staple cylinder Ref. D. When the hammer support base projects beyond the lower limit stop Ref. H, pivot this limit stop to place it under the hammer support and then lock its bolt.

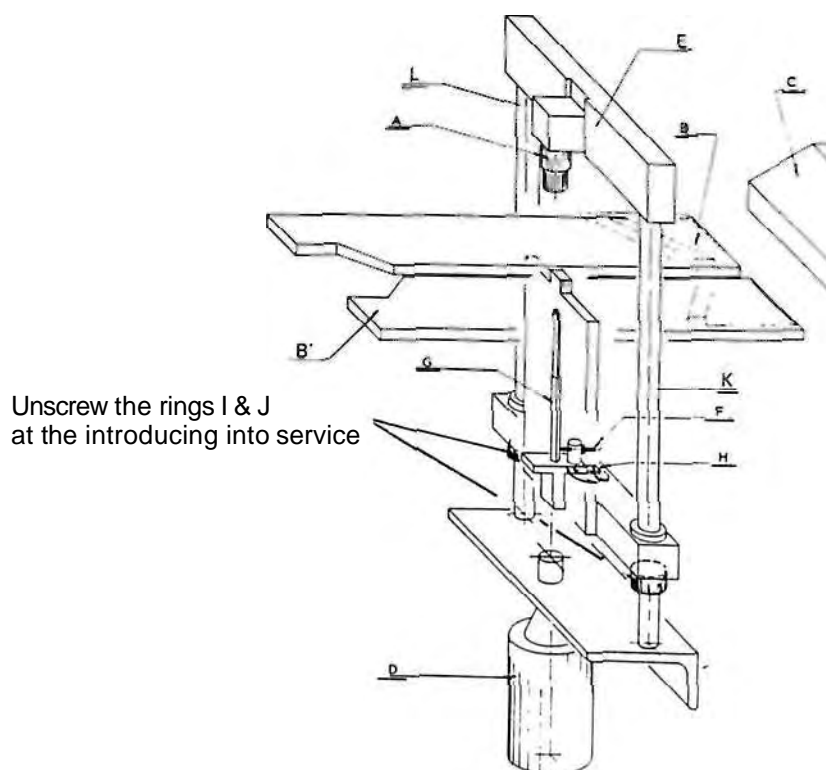

FIGURE 14

II - MAINTENANCE OF THE WEDGE DISTRIBUTION PART

Regularly grease the hammer.

III - MAINTENANCE AND LUBRICATION

If the bracket (Fig. 1 - Ref. E) becomes difficult to slide, oil the horizontal axes (use SAE 20/40 type oil).

Cleaning : Scrape off any glue only when it is DRY.

If glue is used, lightly spray silicon oil (aerosol can) on the two plates; this will facilitate cleaning glue stains after drying.

IV - REMOVING A JAMMED WEDGE (Fig. 15);

If scratching occurs, remove distributor head Ref. H and then remove the jammed wedge. Change the hammer if it is deformed (even very slightly, it must always match the shape of the fixed guide Ref.G).

If the machine is in the middle of a cycle or if you lift the bracket, the distributor head H must be removed in order to replace or remove the wedge engaged in the cartridge.

Maintenance:

Remove the distributor head and clean the cartridge locations, see Fig. 15.

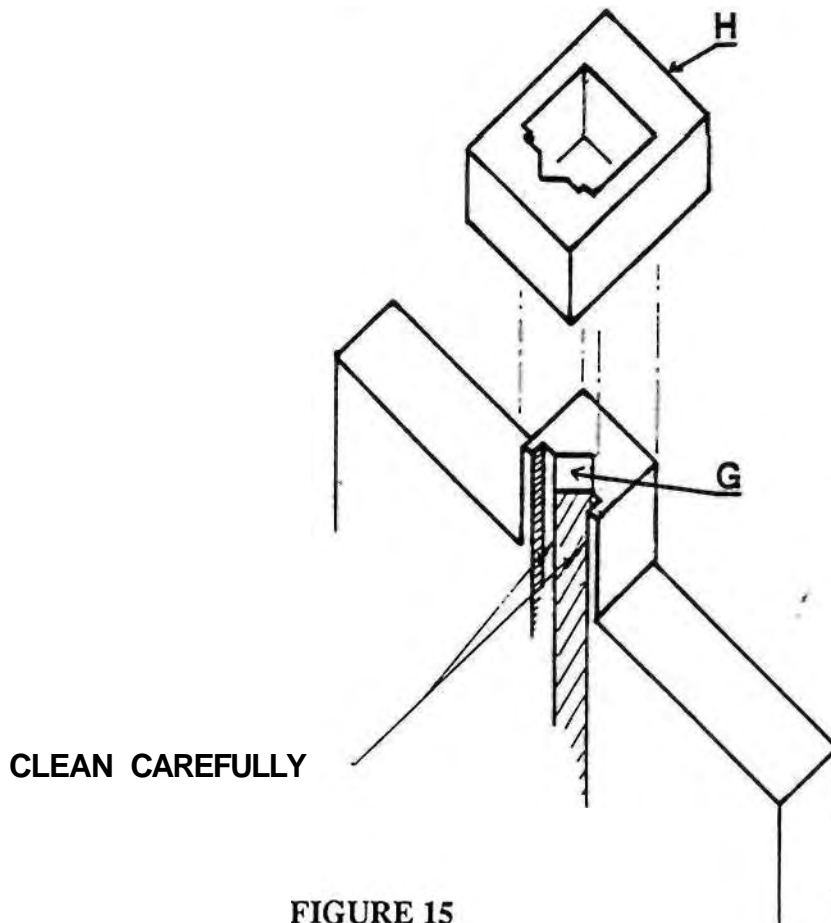

FIGURE 15

FAULT FINDING & REMEDIES			
FAULT	POSSIBLE CAUSES	REMEDIES	PAGES
NO WEDGE ENTERS	C. 1 : The cartridge is empty.	R. 1 : Install a new cartridge	7 - Fig. 7
	C. 2 : The cartridge is badly engaged.	R. 2 : Re-install the cartridge	7 - Fig. 7
	C. 3 : The wedge distributor head is dirty.	R. 3 : Clean it	
	C. 4 : The wedge springs are broken or relaxed.	R. 4 : Check the condition of springs and change them if necessary	13-Fig. 15
	C. 5 : The hammer is broken.	R. 5 : Change the hammer.	12-Fig. 14
THE WEDGE DOES NOT COMPLETELY PENETRATE INTO THE MOULDING	C. 6 : Air pressure below 6 bars	R.6 : Increase the pressure to 6 bars (manometer)	12-Fig. 14 11 -Fig. 13
	C. 7 : Hammer damaged	R.7: Change the hammer	
	C. 8 : Poor adjustment of end of travel limit stop	R.8 : Check the end of travel limit stop adjustment.	8 - Fig. 8
	C. 9 : 40 mm distance not respected	R.9 : Use the correct bung	
	C. 10 : Use of a flexible bung on hard wood	R. 10 : Change the bung or the triangle	1§II
THE WEDGE BREAKS	C. 11 : Hard wood	R. 11 : Use special hard wood wedges.	-
CLAMPING IS INSUFFICIENT ON TWO MOULDINGS	C. 12 : Insufficient clamping pressure	R. 12 : Adjust the clamping pressure	,
CLAMPING IS INSUFFICIENT ON LEFT MOULDING ON RIGHT	C. 13 : Poor adjustment of claws.	R.13 : Repeat adjustment of claws	9 - Fig. 11
POOR ASSEMBLY : - Corner open on the inside or outside. - Opening on the top or bottom of the assembly. - Mouldings are marked by bung or triangle.	C. 14 : Poor adjustment of the assembly corner.	R. 14 : Re-adjust the corner	9 - Fig.9
	C. 15 : Poor adjustment of M & N fences.	R. 15 : Re-adjust these fences before proceeding with assembly	10-Fig. 12
	C. 16 : Use of a hard wood bung on soft wood.	R. 16 : Change the bung to suit the type of wood	
CORNER OFFSET	C. 17 : The mouldings are badly placed.	R. 17: Re-adjust the claw pressure.	9-Fig. 11
LIMIT STOPS MOVE AFTER DRIVING A NUMBER OF STAPLES	C. 18 : Traverse too fast or insufficient clamping of X and Y handles.	R. 18 : Adjust the speed reduction gears on the traverse actuator.	-
THE BRACKET REMAINS AT THE BOTTOM	C. 19 : Max distance between spindle and moulding not respected (40 mm max).	R. 19 : See spindle positioning.	8 - Fig 8
	C. 20 : End of travel detector badly adjusted.	R. 20 : Adjust the end of travel detector.	11 -Fig 13
	C. 21 : Insufficient manometer pressure.	R. 21 : Check minimum pressure 6 bars	
	C. 22 : A foreign body prevents the hammer from completely rising.	R. 22 : Check the hammer support.	
	C. 23 : Machine dirty.	R. 23: Clean.	13
	C. 24 : Use of normal wedges in a hard wood.	R. 24 : Use wedges for hard wood.	

CONTACT YOUR DEALER AFTER SALES SERVICE IF THE PROPOSED REMEDIES DO NOT SOLVE YOUR PROBLEM.